

**KONECRANES C-SERIES  
ELECTRIC CHAIN HOIST**

**Experience  
the difference**



# Efficient performance

The Konecranes C-series is our most advanced electric chain hoist to date. Built smart with the toughness, precision and reliability of our Core of Lifting components, it is designed for more than a million operations. The C-series hoist gives you the ultimate in usability, performance and lifecycle value.

## Boost your productivity

The C-series is a productive lifting partner that will meet the demands of applications lifting loads from as little as 63 kg, all the way up to 5,000 kg. Its Core of Lifting components—designed and manufactured by Konecranes—include a purpose-built motor, controls and gearbox. The C-series enhances the operator experience, boosts productivity and increases long-term reliability with minimal scheduled maintenance.

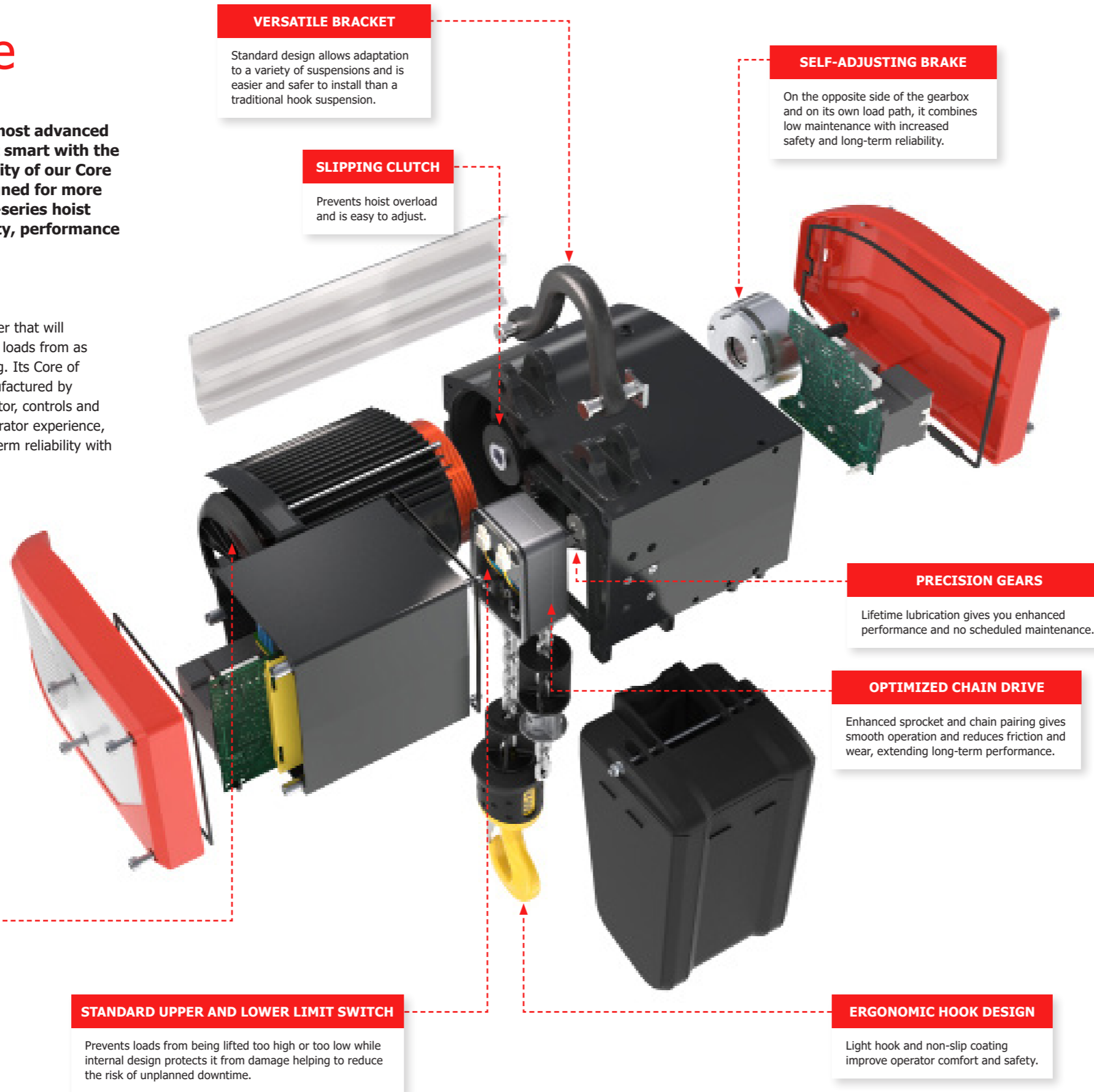

### FLEXIBLE TROLLEY

Modular design for manual or motorized operation and easily adjustable for a wide range of flange widths.

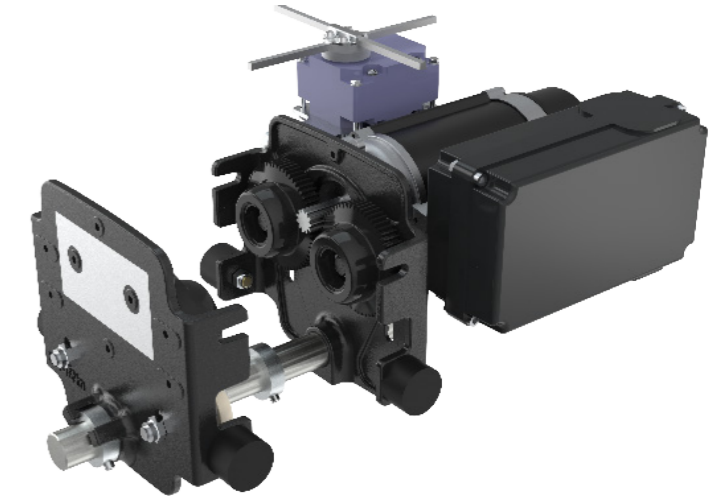

## THE C-SERIES IS IDEAL FOR MANY DIFFERENT INDUSTRIAL APPLICATIONS

**Manufacturing and assembly**  
 Assembly lines consist of several subsequent steps. Products move rapidly from one step to the next as they are put together. Good planning positions lifting devices carefully above each workstation, using space and time efficiently. Lightweight hooks allow easy manipulation.

**Processes**  
 Process applications are different to assembly environments. When cranes are used frequently, durability is important. Resistance against humidity, dust and temperature may be necessary. When C-series hoists are used for maintenance, they may be used less, but they are reliable and ready at a moment's notice.

# Versatility for industrial applications and demanding workstations

Compact headroom, a suspension bracket and a range of other features make C-series hoists easily adjustable for your specific workstation needs.

## Different trolleys for different needs

Maximize safety and productivity with the right choice of trolley for your lifting needs.

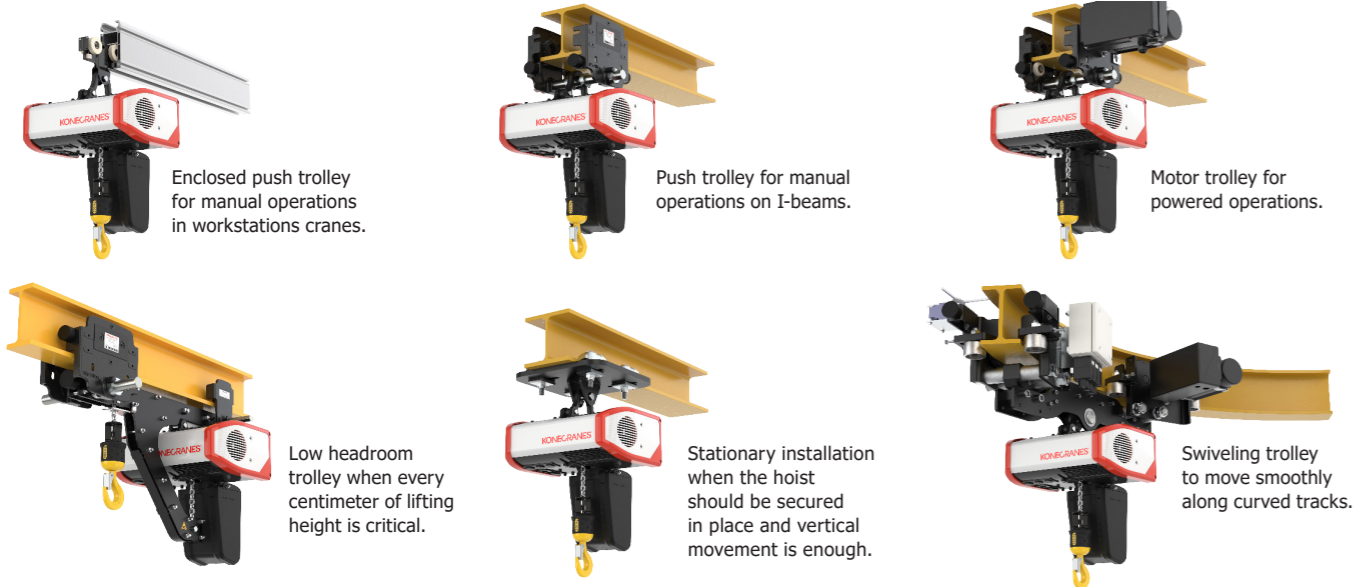

## Different applications with standard hoist suspension

Whether you require precision, smooth motion, a high duty cycle or only occasional lifts, the Konecranes C-series electric chain hoist has the features and options to fit your application. Designed to adapt for a wide range of needs, the C-series installs seamlessly on Konecranes-made equipment such as:

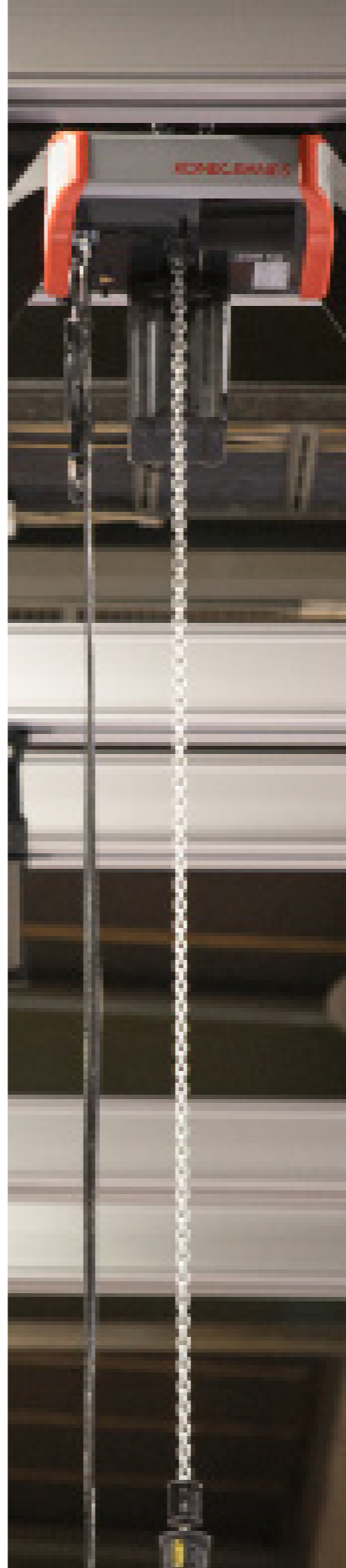
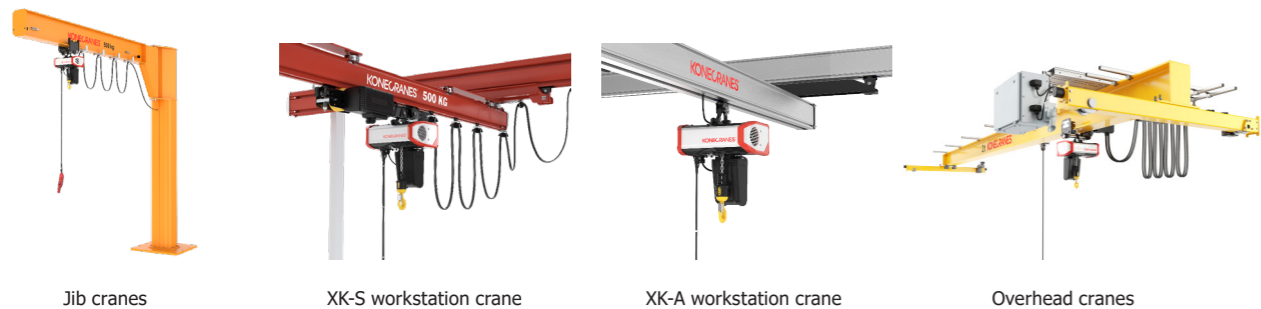

# C-series facts at a glance

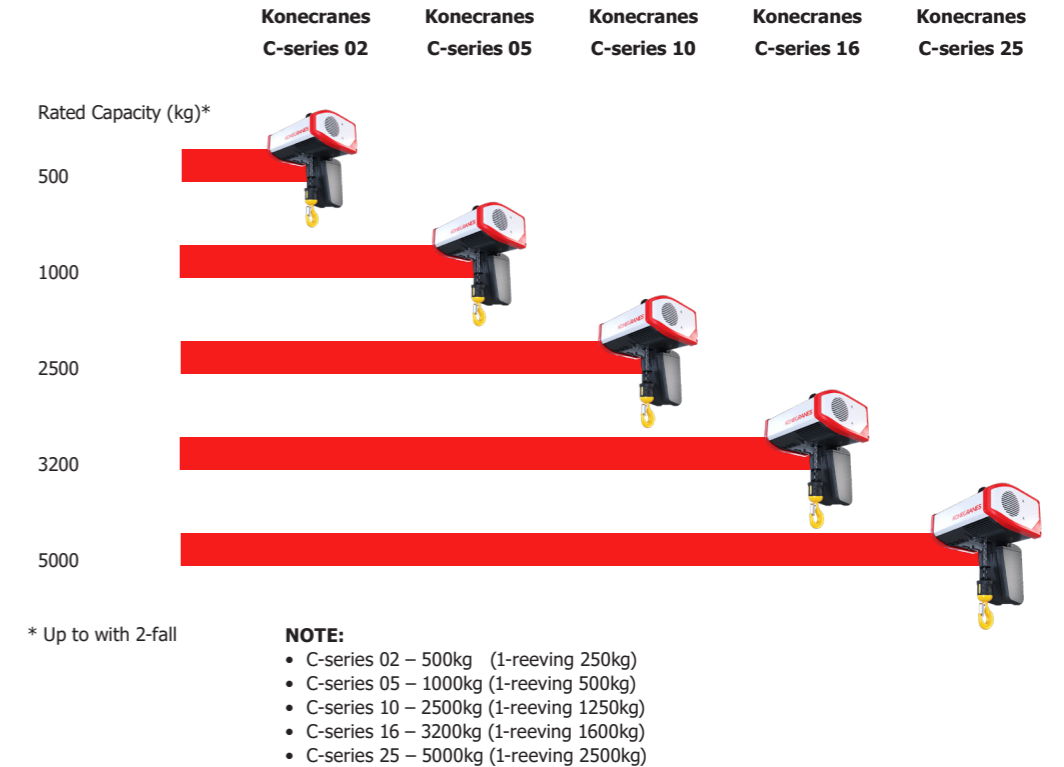

| STANDARD FEATURES     |  |
|-----------------------|--|
| Lifting height        | Lifting heights up to 16 meters with 1/1 reeving, 8 meters with 2/1 reeving        |
| Lifting speed         | Dual speed hoisting with 4:1 speed ratio ranging from 1 m/min up to 16 m/min       |
| Duty classes          | Up to FEM 3m / ISO M6  |
| Motor type            | Motors with TEFC classification, insulation class H, thermal protection            |
| Voltages range        | Wide range of voltages (mains and control) 50/60Hz                                 |
| Overload protection   | With a slipping clutch   |
| Surface treatment     | Hoist body with epoxy powder paint (70µm thickness, C2-M)                          |
| Chain type            | Zinc plated and quenched tempered chain (T class)                                  |
| Emergency stop        | Push button on pendant or radio controller   |
| Hoisting limits       | Mechanical upper and lower limit switches  |
| Protection class      | IP55   |
| Operating temperature | With rated load and speed: -20°C to +40°C (to +50°C with lower performance values) |
| Controllers           | Pendant as a standard and radio as an option                                       |

+ Extensive set of optional features to fulfil all kinds of lifting needs e.g. bigger lifting heights



## The latest in safety and productivity

The C-series electric chain hoist features ergonomic design updates for improved safety and productivity. Intuitive controls enable smooth and efficient operation, with less operator fatigue or chance of human error.

A cleverly shaped hoist and bracket gives the C-series an optimal position, bringing more control and mobility to the working area. The slipping clutch prevents dangerous overloads, and being located on the opposite side of the gearbox to the brake eliminates micro-slipping. The robust design of the hoisting limit switches and emergency stop provide even more safety and usability.

### Even more features with inverter control

For loads up to 2,500 kg, an inverter hoist can further enhance safety and productivity. Stepless hoisting is just the first in a wide range of standard Smart Features. Slack Chain Control and Shock Load Prevention provide smooth lifting movements while protecting product, equipment and people.

Extended Speed Range (ESR) allows faster speeds and better process efficiency with lighter loads or an empty hook. Programmable limits increase safety, optimize the lifting range and speed up cycle times. Inverter hoists are ideal partners for precise assembly work and sensitive parts handling.

## Maximize reliability and performance

The C-series hoist may require less maintenance, but that doesn't mean you can skip it altogether. A program of regular inspections and preventive maintenance supports compliance and helps identify risks and opportunities for improvement.

At Konecranes we take a comprehensive and systematic approach to managing customer assets throughout our Lifecycle Services. We don't just drop off a report on the way out, we consult with you to help guide your decision making. We share our findings, provide recommendations based on our industry-leading expertise and discuss how each action impacts your operations and the entire health of your business.

We have the largest and most extensive service network in the industry giving you the advantage of local inspectors and technicians with access to a wealth of knowledge gained from servicing hundreds of thousands of assets of all makes and models in a wide range of industries.

### EASY MAINTENANCE OF THE C-SERIES HOIST

- The C-series hoist is built for easy installation and serviceability.
- A lifetime lubricated gearbox and self-adjusting magnetic brake that never needs adjustment helps reduce your maintenance downtime.
- You can easily find spare parts for all crane makes and models online at [store.konecranes.com](http://store.konecranes.com).





**Konecranes is a global leader in material handling solutions, serving a broad range of customers across multiple industries. We consistently set the industry benchmark, from everyday improvements to the breakthroughs at moments that matter most, because we know we can always find a safer, more productive and sustainable way. That's why, with around 16,600 professionals in over 50 countries, Konecranes is trusted every day to lift, handle and move what the world needs. In 2022, Group sales totalled EUR 3.4 billion. Konecranes shares are listed on the Nasdaq Helsinki (symbol: KCR).**

© 2023 Konecranes. All rights reserved. 'Konecranes', 'Lifting Businesses' and  are either registered trademarks or trademarks of Konecranes.

This publication is for general informational purposes only. Konecranes reserves the right at any time, without notice, to alter or discontinue the products and/or specifications referenced herein. This publication creates no warranty on the part of Konecranes, express or implied, including but not limited to any implied warranty or merchantability or fitness for a particular purpose.



**CONTACT US TODAY**

[konecranes.com/contact-us](https://konecranes.com/contact-us)

